

Mikron

HEM 600

HEM 800

HEM 1000

HEM 1200



GF Machining Solutions: all about you

When all you need is everything, it's good to know that there is one company that you can count on to deliver complete solutions and services. From world-class electrical discharge machines (EDM), Laser texturing and Additive Manufacturing through to first-class Milling and Spindles, Tooling, Automation and software systems — all backed by unrivalled customer service and support — we, through our AgieCharmilles, Mikron, Liechti, Step-Tec and System 3R technologies, help you raise your game and increase your competitive edge.

Swiss design and quality



Content

Applications	4
Highlights	6
Accuracy	7
Body design	8
Quality - a part of our Highlights	9
Oversized work capacity	10
Around the workpiece	11
Spindles with character	14
Automatic tool magazine	15
Chips and coolant management	16
Control system HEIDENHAIN	17
Options	18
smart machine	19
Technical data	20
GF Machining Solutions	22



Mikron HEM -

Expand your expectations, rally behind innovation.

Mikron HEM. This range of vertical machining center sets standards in the VMC category. Its values are simplicity, modernity and robustness allied with a never before seen price/performance ratio.

The perfect harmonization of both machining performances and stability is the fruit of innovation efforts based on the long experience of our engineers. The result is reliable high precision production equipment with an irreproachable operation in any situation.

The generous standard equipment as well as the vast selection of optional equipment available throughout the range underlines the versatility of this concept of the latest generation.

Today available in four sizes, this new machine line opens the horizon to new performances and quality levels within your daily production.

GF Machining Solutions.

Applications

Efficient production in universal applications



Cardan joint element

X22CrNi17

Aerospace

- + Multiside machining on a dividing head
- + High accuracy
- + Machined from the solid



Custom gripper

AlSi1MgMn

Machine tool industry

- + Machined from the solid
- + Thin wall structure
- + Contour de burring



Baseplate

AlCu4Mg1, 5

Electronic industry

- + Efficient multi-pocket milling
- + Fast positioning
- + High position accuracy
- + Milling, drilling, boring and tapping



Mold base

X153CrMoV12

Mold & Die industry

- + Efficient material removal
- + High geometry accuracy
- + Rigid tapping in steel

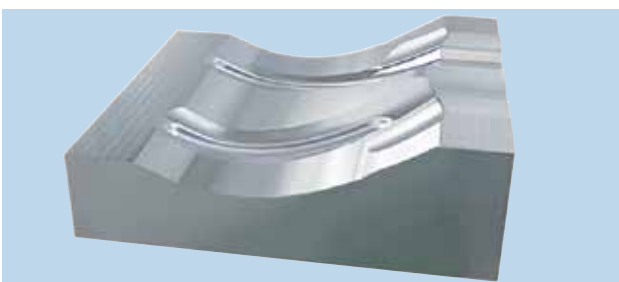

Mold Core

10Ni3MnCuAl (NAK80)

Automotive Industry

- + Efficient material removal
- + Excellent surface quality



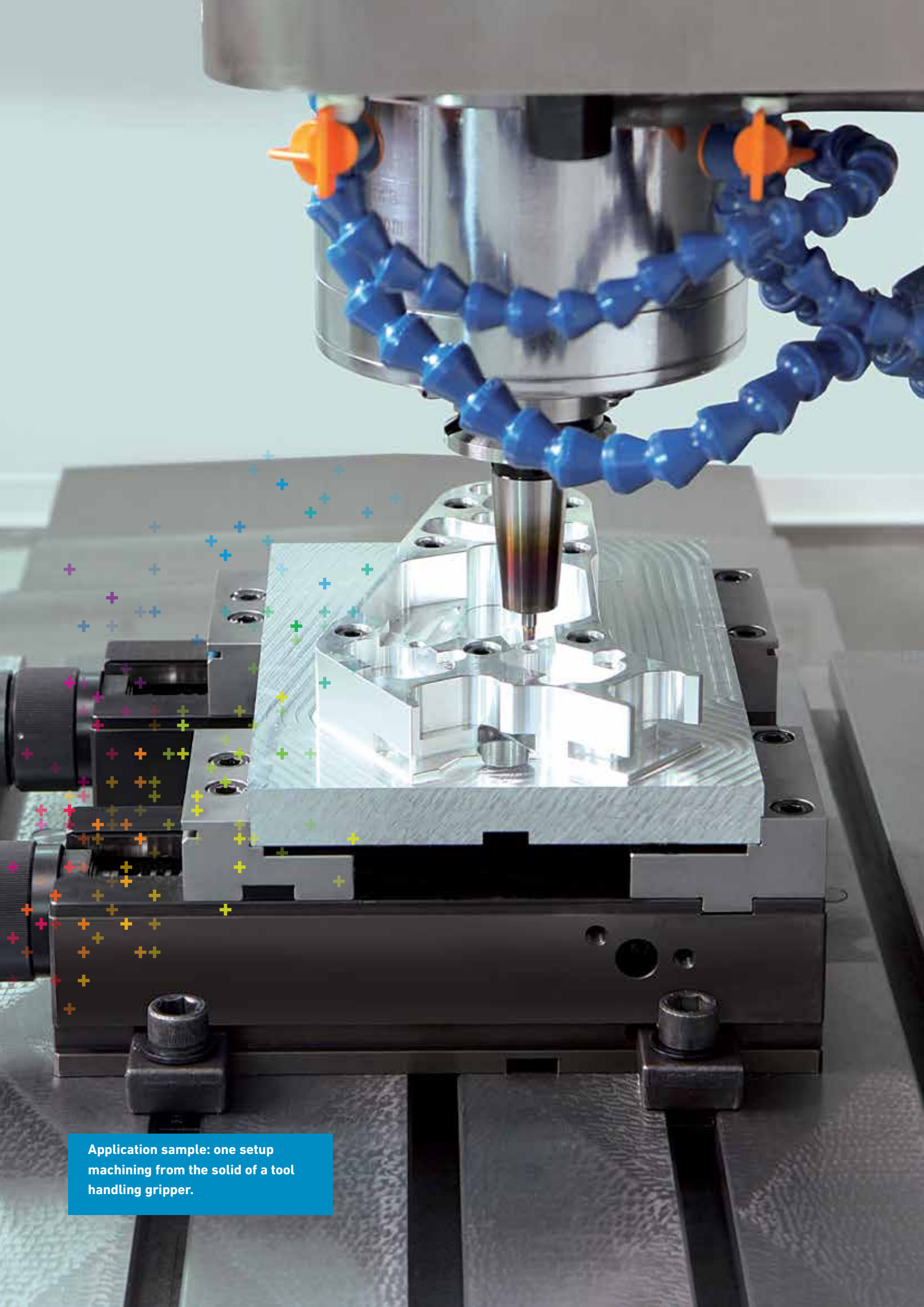

Application sample: one setup machining from the solid of a tool handling gripper.

Highlights

Performance redefined

Easy work area cleaning thanks to a three sided access

Best cover design for ergonomic operating and part loading

Two adjustable air blow hoses and two adjustable coolant hoses

Efficient chip evacuation through smooth inner cover design

Best production overview guaranteed by the operating condition display

Highest path accuracy ensured by state of the art numerical control



Customizable chip and coolant management adapted to your need

Unique divided coolant tank system allowing user friendly maintenance (chip sump)

Safe machine setups thanks to a perfect all-around view to work area

Further highlights

- + Compact construction
- + Best rigidity by high dynamic and maximum reliability
- + Almost all options can be retrofitted
- + Power drives on all axes (no vibration generating counterweight)
- + Security level according to European standards
- + High End numerical control
- + Excellent price/performance ratio

Accuracy

A core component

The Mikron HEM machines fill all preconditions for handling even the very stringent accuracy requirements of the high precision parts production.

Top-performing on part accuracy requires from the machining center:

- + High geometric accuracy
- + High positioning accuracy
- + High dynamic accuracy
- + High thermal accuracy
- + High referencing accuracy

Designed for dynamic accuracy

...“The structural stiffness and high gain position loop are both main criteria in the design of a dynamic precision machine tool“...

- + Optimized static and dynamic stiffness based on FEA analyses
- + High system reaction thanks to powerful drive algorithm
- + High contour fidelity thanks to high look ahead
- + Fast machining at specified accuracy thanks to contour path tolerance

Machined and adjusted in lowest tolerances

The ultimate geometric accuracy of the final assembled structure is the basis for precision machining.

- + Hand scraped geometries
- + Dished clamping geometry ensures a float-free hold

Simpler set-up with workpiece probe OMP 40-2

The infrared probe set into the spindle enables efficient set-up, recognition and measurement of the workpiece (Optional). It shortens setup time considerably.

Safe production with tool probe TS 27

Accurate tool set-up, safe broken tool monitoring - length and diameter of the tools can be measured precisely with the probe mounted on the working table (Optional).

Lasting positioning accuracy

Linear optical encoders are the precondition for machines that must fulfill a high and lasting positioning accuracy by high machining speed.

Indirect measuring systems, also coupled to ballscrew cooling or magnetic encoders are now more efficient under such requirements.

Compensates:

- + Errors due to thermal drifts
- + Errors due to friction variations
- + Errors due to normal wear

We test positioning accuracy according to ISO 230-2:1997.

GF Machining Solutions

Understanding precision...



Keeping accuracy also on long machining time

A stable thermal behavior on the tool center point despite a powerful cutting performance.

- + Main heat sources isolated by coolplates
- + Liquid core cooled casting structure
- + Intelligent thermal control

Body design

Optimized to perfection

Body sculptured machine frame

The machine design, optimized by means of state of the art simulation and analysis tools provide solidity throughout the machining center. The generously sized cast iron construction also stands out due to its excellent vibration absorption properties with high stability and rigidity, even under full load and in continuous operation. The result is a stable milling behavior which ensures a lasting quality of a high accuracy production process.

Strong spindle head

The widely supported and strongly constructed spindle head enables a high-powered milling / drilling operation on the Z-axis. A closed internal coolant circuit stabilizes and controls temperature drifts of the spindle head.

Sturdy belt spindle

The generously sized spindle motor provides uninterrupted production both with high torque at low speeds and high power at high speeds.

The utmost accurate spindle design goes beyond expectations of standard quality to achieve the highest precision and efficiency. The design permits best balance and vibration free milling performance at full speed.

Perfect linear motions

Pre-stressed and double anchored ballscrews ensure the perfect linear motions - an important prerequisite for high workpiece precision.

Linear guides with high rigidity and high load capacity ensure the smoothness in all displacements. Higher machining efficiency is generated through coexistent superior geometrical accuracy and surface quality of the machined work-pieces. The high rigidity makes for better vibration behavior with diminished vibration amplitudes and thus extends tool lives. A central oil lubrication system ensures their highest durability.



Quality - a part of our Highlights

Performance and quality redefined

Quality you can rely on

- + Completely designed and produced by GF Machining Solutions which has dedicated all the know-how of its engineering crew
- + As far as possible, the "carry-over" principle has been applied to maximize the component reliability
- + Structural components have been optimized using newest numerical simulation assistance to reach an ideal solution

Quality you can afford

Conscientious cost control along the design phase led to a product that integrates the best of GF Machining Solutions technologies in a modern, reliable milling machine affordable for a large customer field.

First in its class

Using latest generation control system of famous control and drive suppliers sets new references of performance within 3 axis universal machining.

- + Fast machining at specified accuracy
- + Workshop oriented programming at the machine
- + Conversational man-machine interface

Swissness inside

For over 100 years, machine tools from GF Machining Solutions have proved their quality in their daily use by demanding customers.

While the machines have undergone continuous development during this period, the Swiss principles of quality care have remained the same.

- + Design determined built-in accuracy
- + Meticulous detail care
- + Consistency, Quality, Reliability

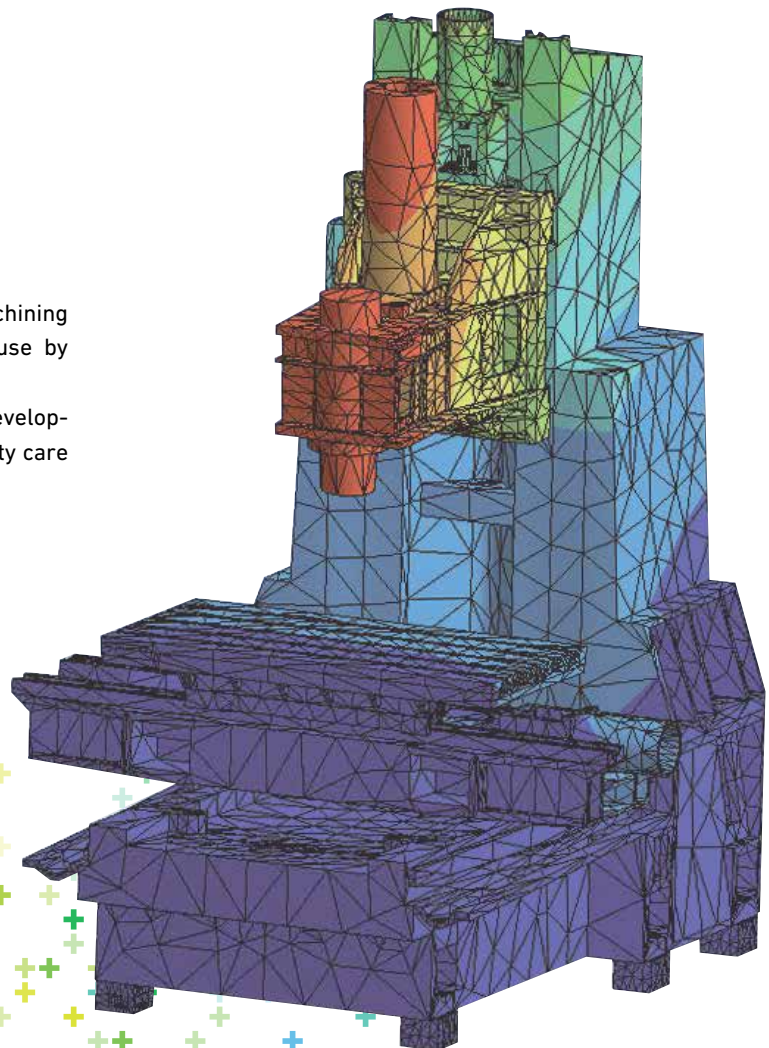

Oversized work capacity

Roomy interior that opens new perspectives...



HEM 1000 and HEM1200 with its two sliding doors allowing direct and ergonomic access to the working table.

Better access to the work area

The Mikron HEM 1000 and 1200 feature a unique "1+1/2" door principle. Safe working is guaranteed by the large screens of the smoothly sliding main door. The side panel ensures that once the door is slid open, there is an optimized access for big part loading or cleaning operations.

Integrated compressed air connection

The table has as standard equipment an integrated air supply that can be used to supply various part clamping systems.

This feature adds flexibility to your choice of the right solution.

- + Fits pneumatically operated zero point pallet clamping systems.
- + Fits pneumatically operated part clamping systems.

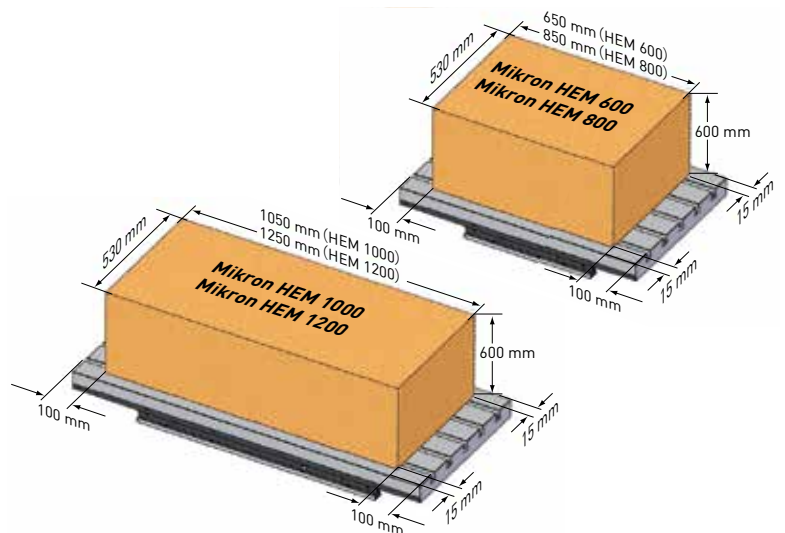

Machining capability over the full travel

The oversized table offers enough surfaces to safely clamp workpieces that have been machined. The dimension ensures that the workpiece can always be clamped. Directly machined in the cast iron, the numerous T-slots permit all imaginable part fastenings and ensure their quick alignment to the machine movements.



Around the workpiece

A good ergonomic working environment that enhances efficiency

Easy crane loading for heavy workpieces

When constructing the cabin, great emphasis was laid on simple and safe crane loading, even with voluminous workpieces. The spacious machining area of every machine version is designed for efficient machining of large and unwieldy parts.



More confidence in what you are doing

Be faster on frequent part setups or program run-in without risks of collision damage.

- + Full 3 sided view
- + Big sized windows
- + Bright illumination of the work area

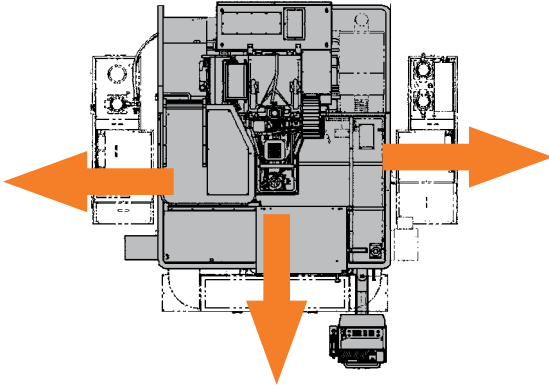

Maintenance of the large coolant tanks is facilitated, since each tank can be rolled out separately.

Standard hand wash and air pistols support the cleaning of parts or machine elements.

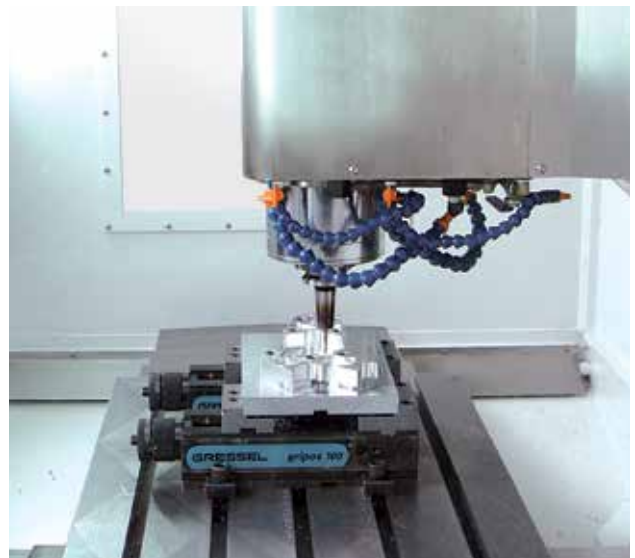

The outstanding feature of Mikron machining centers is their exceptional ergonomics. What is impressive about the concept is its unrivalled accessibility, which is not dependent on the machine's configuration.

The image shows the interior of a Mikron HEM machine. It features a large, multi-axis metal worktable with several parallel tracks. The machine's frame is white, and there are various mechanical components and sensors visible. The text "Mikron HEM - Expand your expectations, rally behind innovation." is overlaid on the image.

**Mikron HEM -
Expand your expectations,
rally behind innovation.**



Spindles with character

A choice of three different spindles is available to meet distinctive application needs

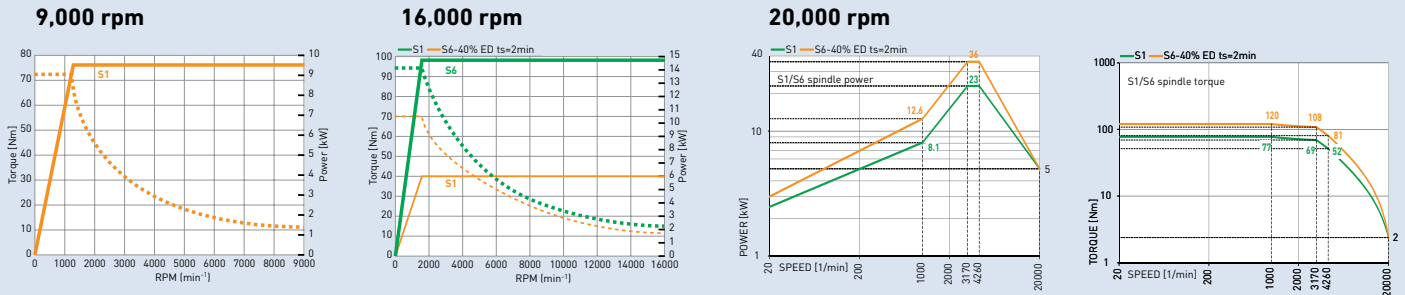

9,000 rpm

The “high torque” spindle version delivers the necessary cutting performance required by hungry big sized tools up to a maximum speed of 9,000 rpm.

16,000 rpm

The inline motor spindle with high torque and high dynamic supports customers how are looking for speed and power in once.

Thanks to the direct coupling the spindle isolates noise and vibrations from the Z slide.

Big size barring supports the efficient milling and rigid cutting. Thanks to the vector driven spindle construction this Spindle delivers a high torque even at lower speed.

20,000 rpm

The cartridge type Step-Tec motor spindle is flange mounted directly into the Z axis slide to minimize thermal distortion and provide ease of maintenance. The spindle taper accepts tool holders to HSK 63A/B standard with retention by a hydro-mechanical system. During tool changing the taper cleanliness is maintained by a continual air blast.

Spindle life is enhanced by large oil/air lubricated hybrid ceramic bearings. The complete spindle is temperature controlled by a controlled spindle refrigerating unit over a closed loop water cooling system. This cooling unit has a large refrigerating capacity and thus allows the machine to be kept constantly refrigerated even in fluctuating temperature environments.

The controlled spindle refrigerating unit is placed by the side of the machine. The tool is cooled by 4 coolant nozzles outside of the spindle.

Cartridge type belt driven spindle

Spindles are the heart of the milling process. They principally determine the cutting performance of the machining center. Its location has always made it subject to damage.

- + Fits high power and torque
- + Low maintenance requirements
- + Low replacement costs
- + Compensated thermal drifts

Quiet and smooth at high speed

Helical Offset Tooth design merges both belt and sprocket in the quietest, smoothest and most compact synchronous drive package available.

- + Lower noise
- + Less vibration
- + Narrower drive
- + Energy saving
- + Technical strength

Automatic lubrication

The uninterrupted machining at maximum rotation speed is possible on the 14k spindle thanks to the automatic regreasing capability.

- + Long-term lubrication
- + Low lubricant consumption
- + Cost savings
- + Reduced maintenance

Automatic tool magazin

Faster and uninterrupted production



Safe and reliable working

All tools are optimally protected from chip contamination since the tool changer is separated from the working area.

- + Contamination protected tool storage
- + Checking window enhances operation safety

Minimized non productive times

Because every human intervention within the machining process is a potential error source and wastes time.

- + Side-mounted automatic tool changer
- + High capacity storage
- + Fast gear cam driven double arm gripper system



Chips and coolant management

Clean & easy

The triple benefits of high flow flushing

- + Ensures good lubrication of the cutting edge.
- + Prevents premature tool wear and reduces the local heat transfer which enhances the machining accuracy.
- + Avoids chip accumulation around the cutting process and facilitates their evacuation.

Always guaranteed by:

- 2 adjustable high flow coolant nozzles
- 2 adjustable air blow off nozzles

Cooling from all directions

The integrated nozzles located around the spindle eliminate any difficulties in adjusting single cooling jets on complex part geometries.

Cooling through the spindle, 20 or 50 bar

The coolant is guided under high pressure through the work spindle directly to the cutting edges. The advantages are higher cutting speeds, problem-free peck drilling, blind hole milling and extended service life of tools.

Smooth inner cover design

Great attention has been paid to the flow of chips in the working area.

Sharply inclined side walls optionally combined with flushing systems direct chips straight to the evacuation channels.

The chips are then efficiently transported out of the work area by chip conveyors.



Standard hand wash and air pistols support the cleaning of parts or machine elements.

Programmed predictability

Time-consuming and imprecise manual adjustments of the coolant supply are things of the past. The programmable coolant nozzle automatically directs the jet after each tool change exactly to the point of the operation (Optional).



Control system HEIDENHAIN

The new TNC 620 offers quick and reliable Machining with High Contour Fidelity

Heidenhain's Touch Numerical Control, the TNC made its mark in the demanding tool and moldmaking industry. It is recognized by experts as the numerical control offering best performances and programming comfort. The newest model, the TNC 620 once again merits this reputation.

User friendly human interface

The 15-inch TFT color monitor shows a clear overview based on graphic supports in any situation

- + Safer programming: each traverse command is drawn on the screen
- + Faster programming: each cycle parameter is graphically illustrated
- + Fast data transfer from programming stations.

Quick programming and part setups

TNC 620 features application-oriented setup functions that help to reduce non-productive time.

- + Straightforward function keys for complex contours
- + Field-proven cycles for recurring operations
- + Re- using of programmed contour elements
- + Workpiece presetting
- + Workpiece misalignment compensation
- + Easy machining under handwheel control



Options

Fit the machine to your process requirements

Machining another dimension

The precision dividing heads available all over the product line bring another dimension in the machining capacity of your Mikron HEM .

Therefore, a connection interface of a 4th axis is directly foreseen in the work area. Removing or connecting the dividing head is therefore problem-free and possible at any time.

Numerous accessories are available for an easy but safe clamping of the different part geometries.

- + Max rotational speed: 44 min⁻¹
- + Center height: 160 mm
- + Max load: 75 kg (with tailstock: 150 kg)
- + Pneumo- hydraulic axis clamp
- + Heavy duty, high precision cross roller bearings
- + Dual lead worm with high efficiency and increased tooth depths



Dividing head

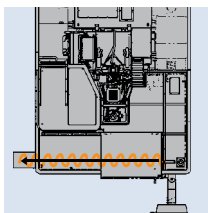

Front conveyor

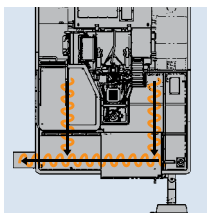

Front and side conveyor



Programmable coolant nozzle

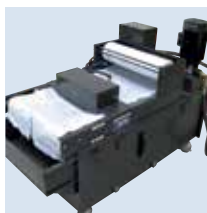

TSC 20 or 50 bar supply unit



Mist extraction unit

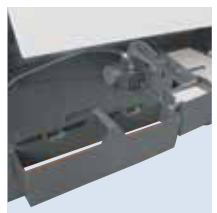

Mechanical oil/coolant separator



Heidenhain TNC 620 hand wheel



Beacon



Glass scales



OMP 40-2 touch probe



TS 27 table touch system

smart machine

The new dimension in modern production

Bringing intelligence into the milling process is the intended aim of “smart machine”.

This includes a range of modules that are collectively referred to under the generic term “smart machine” and that fulfil various functions. In order to make the milling process “intelligent”, various requirements have to be implemented.

First of all, establishing comprehensive communication between man and machine, which makes precise information that the operator requires to assess the milling process available to him. Secondly, supporting the operator in the optimisation of the process, which considerably improves the performance. Thirdly, the machine optimises the milling process, which improves the process safety and the quality of the workpiece - above all in unmanned operation.

The facts

- + Greater accuracy in shorter machining times
- + Increase in the workpiece surface quality as well as the surface and shape accuracy
- + Recognition of critical machining strategies
- + Improvement in the process safety
- + Reduction of the machine set due to longer service life
- + Higher availability
- + Better operating comfort
- + Considerable increase in reliability in unmanned operation

smart machine construction kit system

Each of the modules fulfils a specific task. Just like in a construction kit, the user can select the modules that seem to him to be the best option for improving his process.

Your benefit

Producing the workpieces in a process-secure and precise manner, increasing the reliability in unmanned operation, increasing the service life of the machine and significantly reducing production costs.



Saving energy



Protection



Precision



Productivity

The smart machine is constantly being further developed.
The currently available modules can be found at
www.gfms.com

Technical data



			Mikron HEM 600	Mikron HEM 800	Mikron HEM 1000	Mikron HEM 1200
Working Range						
Longitudinal	X	mm	650	850	1050	1250
Transverse	Y	mm	530	530	530	530
Vertical	Z	mm	600	600	600	600
Table						
Table size		mm	850 x 560	1050 x 560	1250 x 560	1450 x 560
Max. weight on table		kg	600	800	1000	1200
Distance table - spindle		mm	150 - 750	150 - 750	150 - 750	150 - 750
Feed drives						
Feed	Heidenhain X, Y, Z	m/min ⁻¹	15	15	15	15
Rapid speed	Heidenhain X, Y / Z	m/min ⁻¹	35* (30) / 24	35* (30) / 24	35* (30) / 24	35* (30) / 24
			* with work load up to 250 kg only			
Spindle 100% ED, S1						
9'000 rpm, BT 40	Heidenhain	kW / Nm	9.5/71	9.5/71	9.5/71	9.5/71
16'000 rpm, ISO/BT 40	Heidenhain	kW / Nm	15 /94	15 /94	15 /94	15 /94
20'000 rpm, HSK-A 63	Heidenhain (S6)	kW / Nm	26.0/91.0	26.0/91.0	26.0/91.0	26.0/91.0
Tool magazine						
Umbrella type	BT 40	pce.	24	24	24	24
Drum type	BT 40	pce.	30	30	30	30
Drum type	HSK-A63	pce.	30	30	30	30
Max. tool length		mm	300	300	300	300
Max. tool diameter		mm	80 / (125)	80 / (125)	80 / (125)	80 / (125)
Max. tool weight		kg	6	6	6	6
Control						
Heidenhain	TNC 620		+	+	+	+
Machine weight						
		kg	6900	7000	7600	7700
smart machine						
	Heidenhain		ITC, APS, APS extended, OSS, PFP	ITC, APS, APS extended, OSS, PFP	ITC, APS, APS extended, OSS, PFP	ITC, APS, APS extended, OSS, PFP

Mikron HEM 600
Mikron HEM 800

Mikron HEM 1000
Mikron HEM 1200

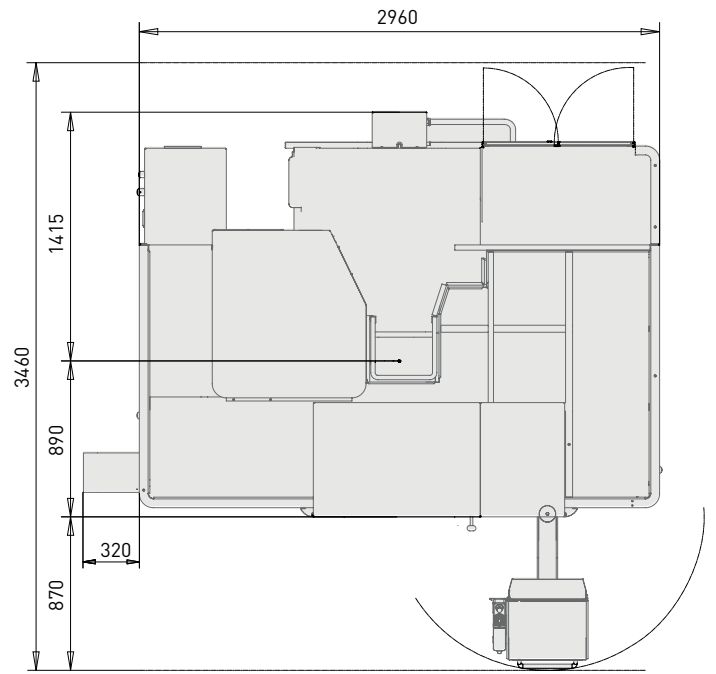
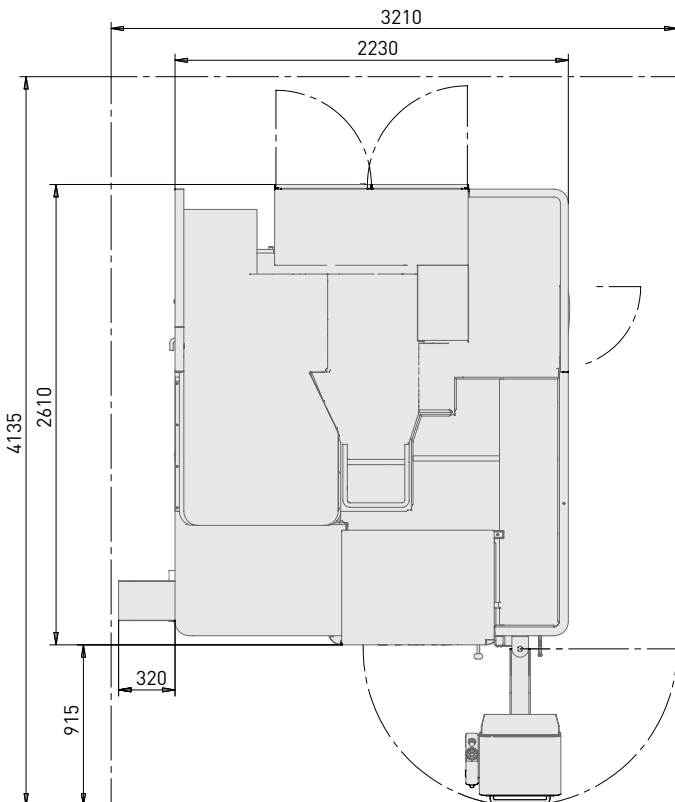
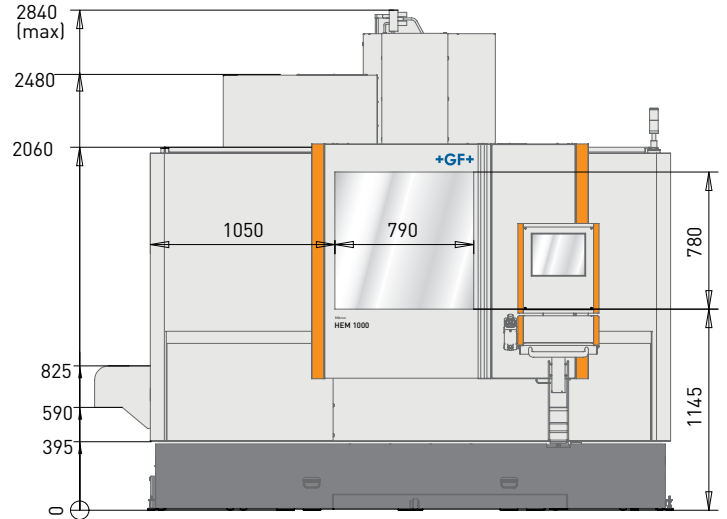
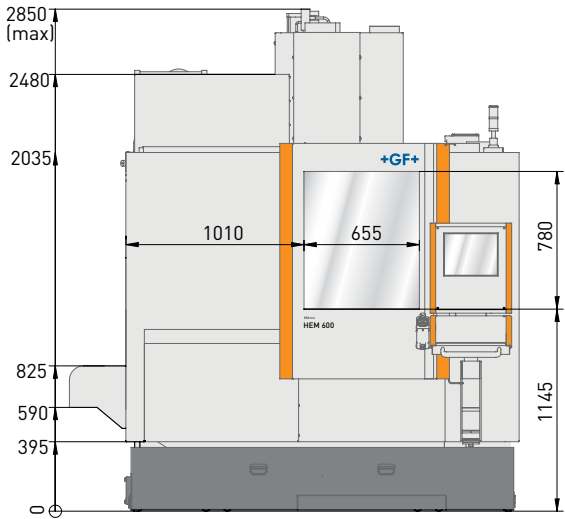

GF Machining Solutions



EDM (electrical discharge machining)

AgieCharmilles wire-cutting, die-sinking and hole-drilling machines

For over 60 years we have been at the forefront of every EDM development: designing and refining the EDM process and building machine tools that deliver peerless part accuracies, surface finishes, cutting speeds and process reliability. Today, our AgieCharmilles wire-cutting, die-sinking and hole-drilling machines are recognized throughout the world as the best in the business. Our continuous research and development in digital generator technology, control systems and integrated Automation systems are evidence of our commitment to keeping your EDM operations on the leading edge of technology.



Laser

AgieCharmilles Laser texturing machines

Laser texturing is a fully-digitized surface engineering process that has huge potential. The technology enables precise 2D and 3D textures or engravings to be machined accurately and directly onto complex parts or molds to improve and alter their aesthetic appeal, functionality and performance. The process is infinitely repeatable and offers many distinct environmental and economic advantages over conventional texturing processes.

Laser Additive Manufacturing (AM)

GF Machining Solutions has partnered with EOS, the global leader for high-end AM solutions, to integrate this innovative technology and further develop it into its current solutions to fully benefit the mold industry, by focusing on injection efficiency: optimized cooling design to reduce cycle time, lower energy consumption, higher quality of plastic parts.



Tooling and Automation

System 3R Tooling, Automation and software

Productivity is the key to manufacturing success, and automating a manufacturing process is a proven method of increasing its efficiency, effectiveness, quality and reliability. System 3R's integrated Tooling, Automation and software solutions ranging from simple workpiece pallet and electrode changers through to flexible manufacturing and robot handling systems are guaranteed to help you increase their competitive advantage.



Milling

Mikron high-speed (HSM), high-performance (HPM) and high-efficiency (HEM) Milling centers

Customers operating in the mold, tool and die and precision component manufacturing sectors stake their reputations on being able to quickly and cost-competitively meet their customers' demands. That's why they invest in GF Mikron machines. Incorporating the latest and most advanced technologies and premium-performance components, Mikron HSM, HPM and HEM machines help you increase your production capabilities and improve your productivity. Designed and built for speed, accuracy and reliability, the machines, like you, are proven performers.

Liechti dedicated aerospace and energy machining centers

Aerospace and power generation turbine manufacturers increasingly turn to Liechti dedicated five- and six-axis machining centers to machine complex, high-precision airfoils on blades, disks, blisks, blisks/IBRs and impellers. It's easy to see why because these machines, with their specific profile machining technology, specialized CAD/CAM software and engineering competence for ultra-dynamic machining in titanium, Inconel, nimonic, titanium-aluminide and high-alloy steels, yield productivity gains as much as 30 percent, thanks to reduced machining times. In the globally competitive aerospace and power generation manufacturing sector, that's definitely worth shouting about.

Step-Tec Spindles

At the heart of every GF Mikron machining center is high-performance Step-Tec Spindle. Step-Tec Spindles are essential core components of our machining centers. Highly accurate and thermally stable Step-Tec Spindles ensure that our machines can handle everything from heavy-duty roughing to fine-finishing operations.



Customer Services

Operations Support, Machine Support and Business Support

To help you get the most and the best from your machine tools and equipment, we offer three levels of support. Operations Support covers our range of original wear parts and certified consumables (EDM wires, filters, resins, electrodes etc.) to ensure that your machines are performing at the highest levels. Machine Support maximizes, through our best-in-class technical support, preventive services and quality spare parts, your machine tool uptime. Business Support is designed to help you make a real step-change in your productivity and performance with solutions tailored to your specific needs.

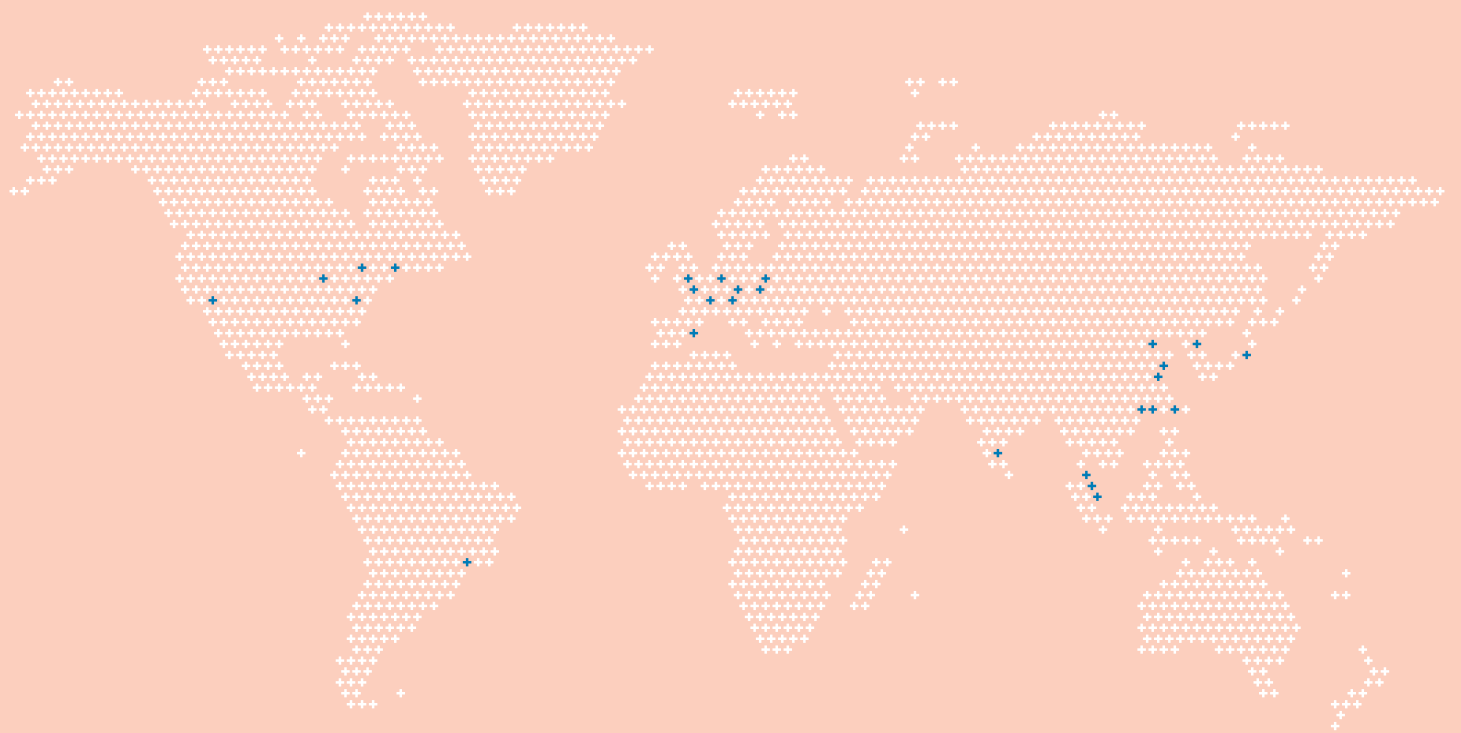

At a glance

We enable our customers to run their businesses efficiently and effectively by offering innovative Milling, EDM, Laser, Additive Manufacturing, Spindle, Tooling and Automation solutions. A comprehensive package of Customer Services completes our proposition.

www.gfms.com

