



Professional High-Speed Machine



Establishment in 1995, GENTIGER has become is the name equal to "High Speed Cutting Expert". Our company spirit, "Perfection, Efficiency, Specialization" is embedded in all GENTIGER machines, as we deliver comprehensive machines and services to our customers worldwide.



## Gentiger Machinery Industrial Co., Ltd.

No. 2-2, Shueitou Lane, Jiahou Rd, Waipu Dist.,  
Taichung City 438, Taiwan.

TEL: 886-4-2683-6919      FAX: 886-4-2683-9900

[Http://www.gentiger.com.tw](http://www.gentiger.com.tw)

E-mail: [gentiger@ms38.hinet.net](mailto:gentiger@ms38.hinet.net)

147351001212E

# GT-105V

High Speed Double Column Machining Center

[www.gentiger.com.tw](http://www.gentiger.com.tw)

CE ISO 9001

# GT-105V

01 ◀ ▶ 02

How is the Gentiger GT-105V so different from other conventional machining centers?

*The Gentiger GT-105V is a large capacity, rugged machine that handles precision machining with higher efficiency than conventional machining centers.*

- ▷ Oil fluid separation design
- ▷ Built-in high speed spindle
- ▷ Tool magazine capacity: 16 tools
- ▷ Max. rapid feedrate: 30 m/min.
- ▷ Max. cutting feedrate: 20 m/min.
- ▷ Table area: 1100 x 600 mm
- ▷ X, Y, Z-axis travel: 1000 x 600 x 500 mm
- ▷ Siemens 840D/828D controller with high speed mill, NURBS interpolation function (optional: Fanuc, Heidenhain and Mitsubishi)



# GT-105V

## Optimized Structure of Rigidity and Stability

### Ø40 mm Extra Large Ball Screws

The Gentiger GT-105V employs extra large ball screws for transmission. They provide extra powerful transmission force without deflection problems.

### THK-45SRG Rigid Linear Guide Ways

The use of extra heavy duty, high speed, roller-type linear guide ways from THK provide outstanding features, such as low thermal growth, low noise, extra low surface pressure and an excellent lubrication effect. The linear guide ways effectively suppress thermal growth and feature long life, while remaining maintenance free for a long time.

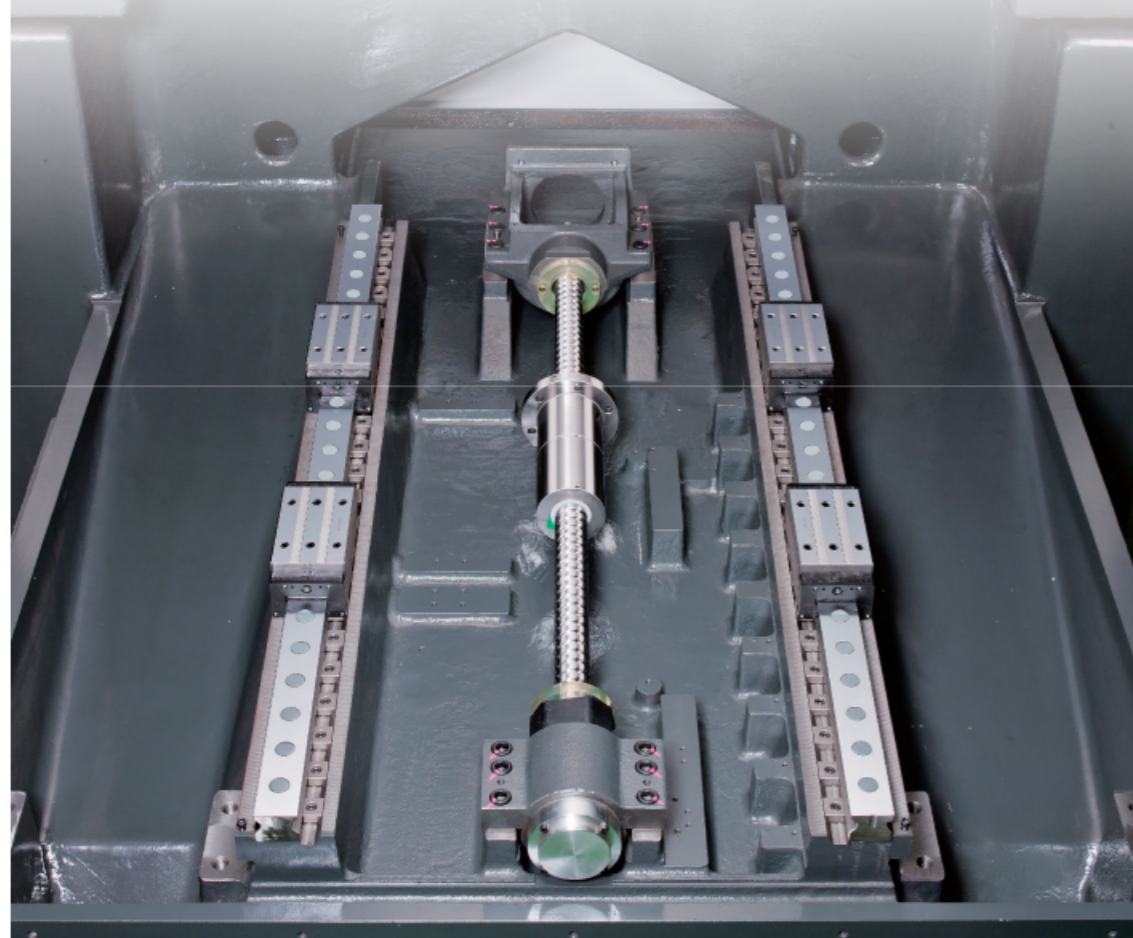

03 ◀▶ 04



- ▷ Superior rigid structure is constructed with FC-30 high quality cast iron. The width of the column is the same as the base.
- ▷ All cast iron is tempered and season-treated for over two months to thoroughly relieve internal stress.
- ▷ After coarse machining, cast iron is stored for over 30 days to further relieve stress before performing fine machining.
- ▷ Y-axis linear guide ways are independently mounted on the base. The workpiece moves only on the Y-axis without loading from the saddle on the X-axis.
- ▷ X-axis linear guide ways are independently mounted on the top of the column without the load of the workpiece.
- ▷ X, Y and Z-axis ball screws are directly connected to servo motors by couplings to prevent accumulated errors due to a belt transmission.
- ▷ Positioning accuracy: 0.005 mm / Full Stroke. (ISO-230-2)
- ▷ Repeatability accuracy: <0.004 mm / Full Stroke. (ISO-230-2)

# 15,000 / 24,000 rpm High Speed Spindle



15,000 rpm Direct Drive Type Spindle

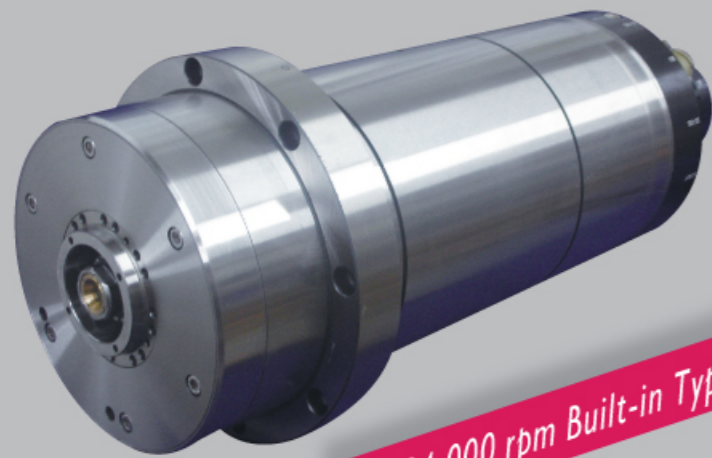

24,000 rpm Built-in Type Spindle



24,000 rpm Built-in Type Spindle  
Position sensor (Optional)

The high speed spindle contributes to efficient machining and a finer surface finish. The Gentiger GT-105V provides a 15,000 rpm direct-drive spindle a 24,000 rpm built-in spindle to choose from.

High precision, High rigidity, High power, Low vibration, No noise, Extends the life of tools

| TYPE                                       | T15                     | Y24A          | S24A           |
|--------------------------------------------|-------------------------|---------------|----------------|
| Max. speed                                 | 15,000 rpm              | 24,000 rpm    | 24,000 rpm     |
| Bearing lubrication                        | Grease / Oil air (opt.) | By oil air    | By oil air     |
| Spindle motor type                         | Direct drive type       | Built-in type | Built-in type  |
| Spindle motor                              | 11 Kw                   | 18 / 23 Kw    | 30 / 39 Kw     |
| Spindle torque output                      | 74 / 130 Nm             | 29 / 37 Nm    | 29.1 / 38.7 Nm |
| Tool shank type                            | BBT / BT 40             | HSK-A63       | HSK-A63        |
| Inside dia. Of spindle bearing             | Ø70 mm                  | Ø65 mm        | Ø65 mm         |
| Cutter needs to be dynamically balanced to | Within G2.5             | Within G2.5   | Within G2.5    |

## Power Diagram / Spindle Torque

### T15

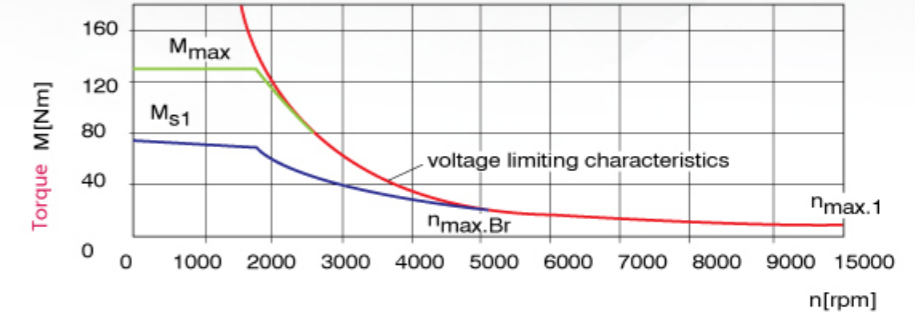
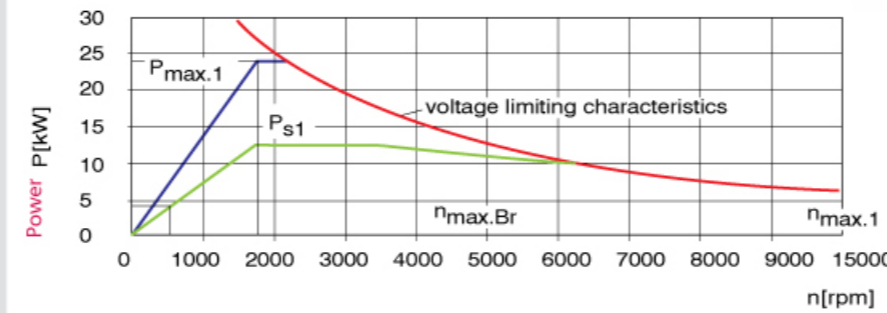

## Power Diagram / Spindle Torque

### Y24A

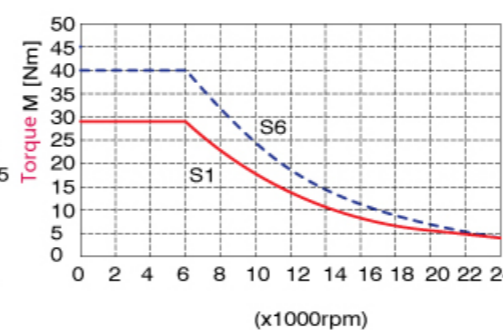
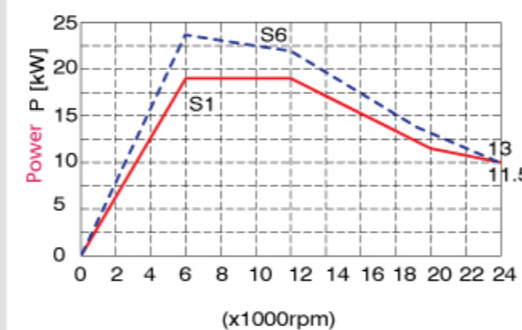

### S24A

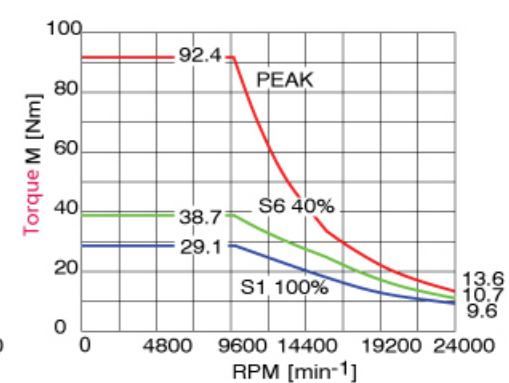
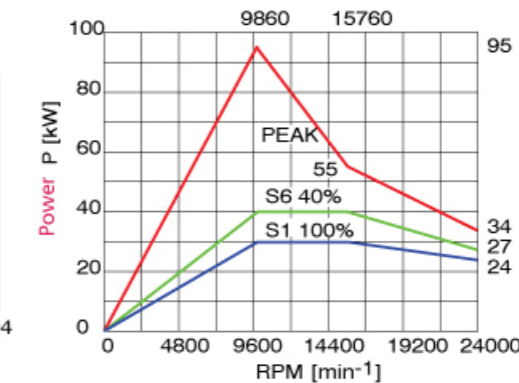

# Cutting Test Report

## Accuracy Inspection by Laser

The high-tech Renishaw laser unit is applied for inspecting linear positioning accuracy, pitch error and backlash, etc.

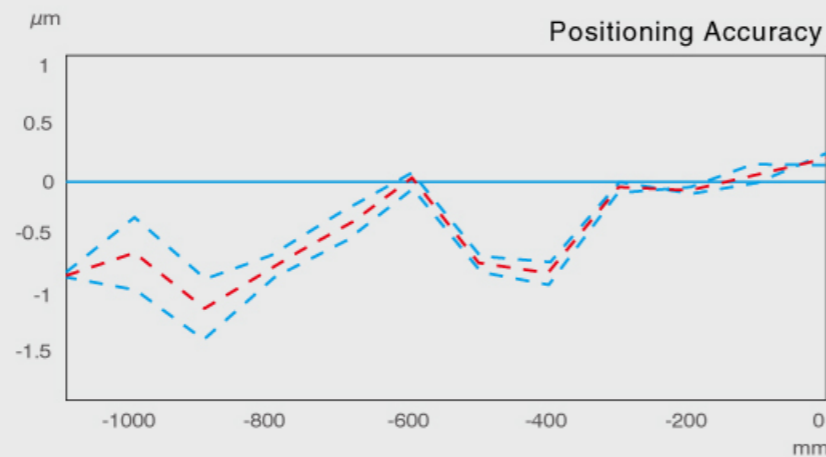
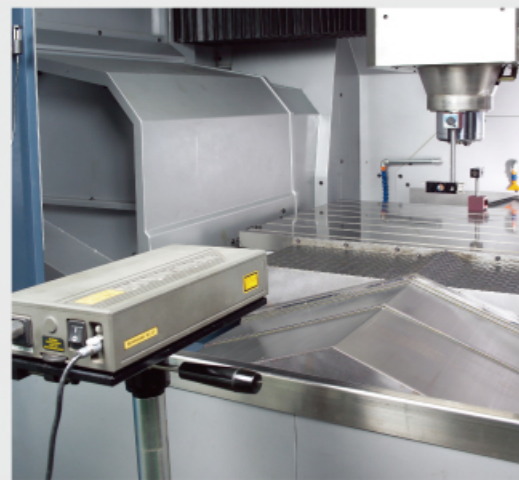

# Perfectly Suited for High Speed Precision Cutting

The Gentiger GT-105V is well suited for 3C, automotive, die and mold, aerospace and precision parts industries. Whatever high precision machining is required, this machine is your best choice.

Workpiece: IRREGULAR SHAPE  
 Controller: SIEMENS 840D  
 Workpiece Size: 100 x 100 x 55 / mm  
 Material: NAK80 / HRC42  
 Type of Tool: R5 / R1  
 Machining Time: 4 H 49 M

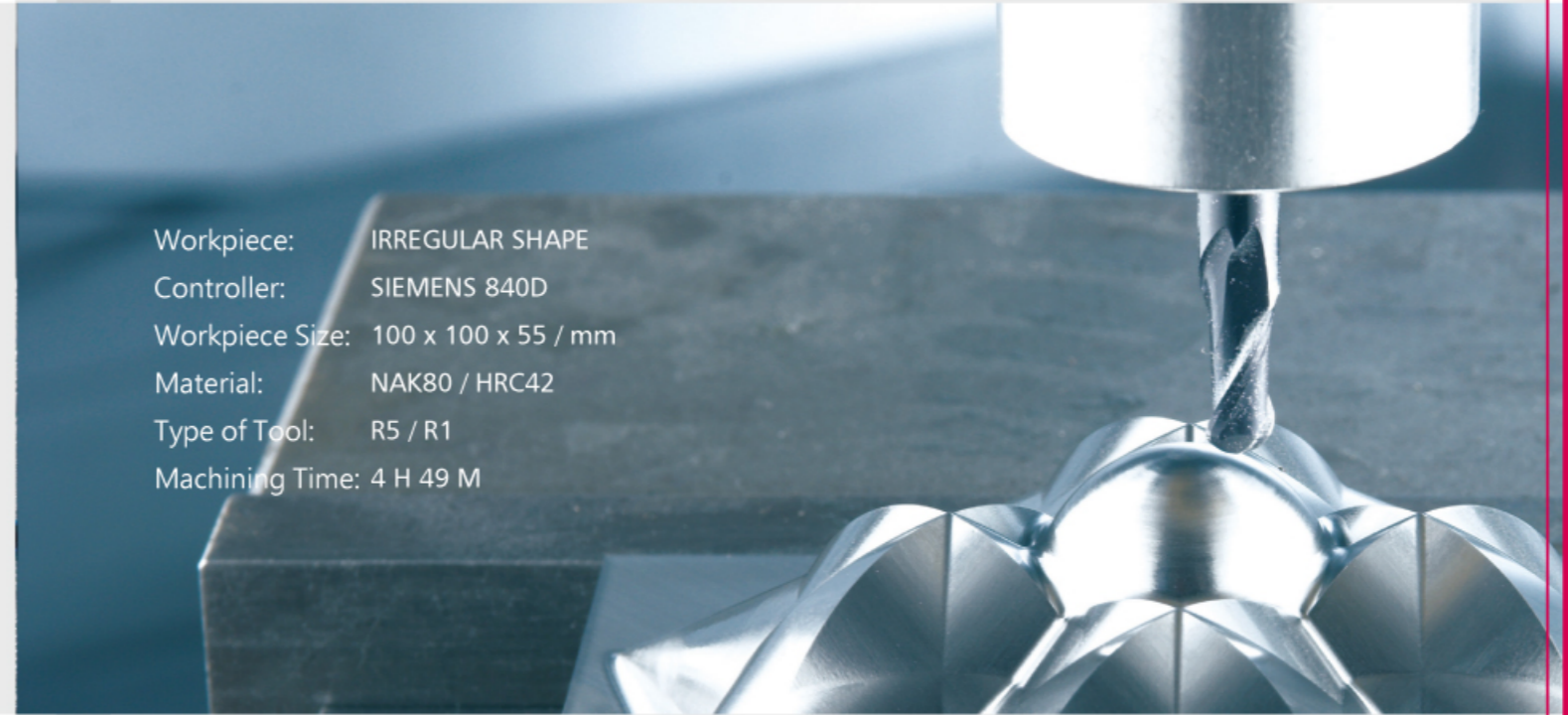

## Ball Bar Circulating Accuracy Inspection

A high precision Renishaw ball bar tester is used for inspecting servo accuracy and geometric errors between two axes, thereby ensuring outstanding circularity accuracy.

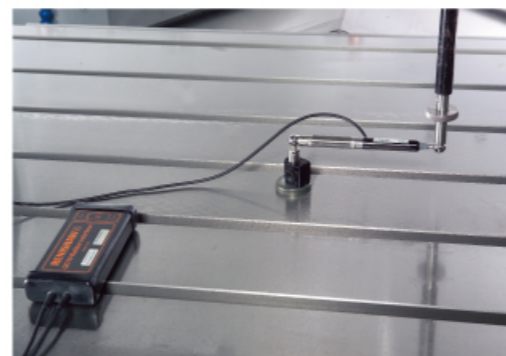

## Positioning and Repeatability Accuracy

### GT-105V

|                      |                                           |
|----------------------|-------------------------------------------|
| Control              | SIEMENS / FANUC / HEIDENHAIN / MITSUBISHI |
| Positioning Accuracy | 0.005 mm / Full Stroke. (ISO-230-2)       |
| Repeatability        | <0.004 mm / Full Stroke. (ISO-230-2)      |

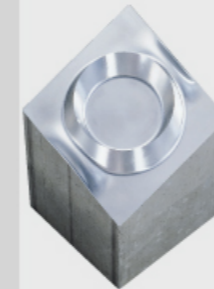
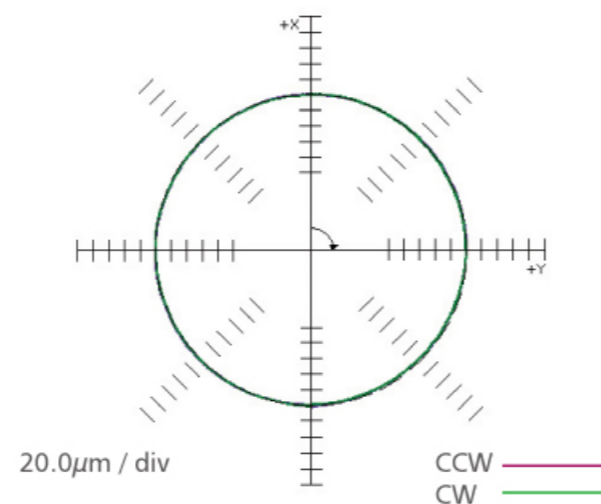

Workpiece: SHARP EDGE  
 Controller: SIEMENS 840D  
 Workpiece Size: 100 x 100 x 120 / mm  
 Material: AL6061  
 Type of Tool: R5 / R4  
 Machining Time: 47 M

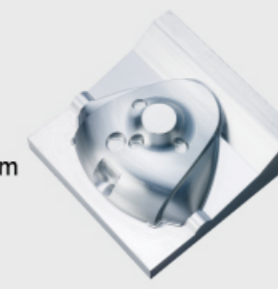

Workpiece: GOLF CLUB HEAD  
 Controller: SIEMENS 840D  
 Workpiece Size: 155 x 155 x 85 / mm  
 Material: AL6061  
 Type of Tool: R4 / R1  
 Machining Time: 1 H 5 M



Workpiece: WRENCH MOLD  
 Controller: SIEMENS 840D  
 Workpiece Size: 290 x 70 x 40 / mm  
 Material: NAK80 / HRC42  
 Type of Tool: R4 / R0.5  
 Machining Time: 2 H 24 M

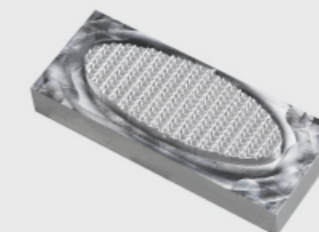

Workpiece: REFLECTION PAD  
 Controller: SIEMENS 840D  
 Workpiece Size: 98 x 40 x 20 / mm  
 Material: NAK80 / HRC42  
 Type of Tool: R1 / R0.4  
 Machining Time: 1 H 23 M

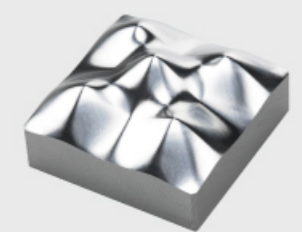

Workpiece: IRREGULAR SHAPE  
 Controller: SIEMENS 840D  
 Workpiece Size: 60 x 60 x 350 / mm  
 Material: NAK80 / HRC42  
 Type of Tool: R5 / R2  
 Machining Time: 51 M

# Outstanding Design Concept With Robust Structure, Offering Extremely Stable Platform For High Speed Cutting

## 1. Effective Flood System

Powerful flood system for flushing chips with several additional nozzles and coolant system. Utilization of independent pump ensures efficient cooling of workpieces and chip flushing during machining.

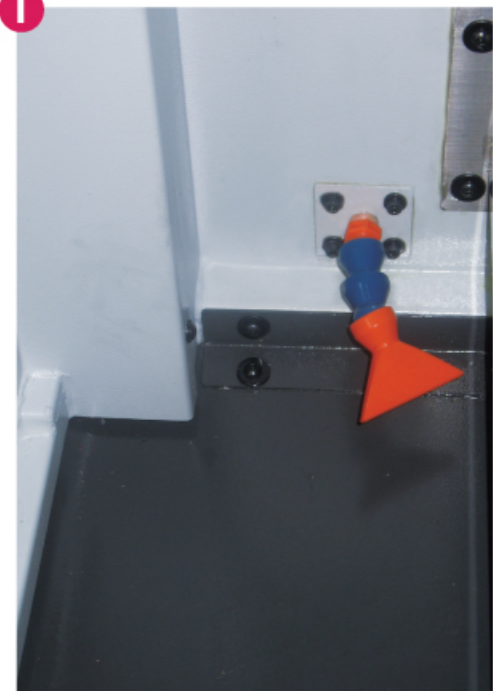

## 2. Collective Lubrication System

The lubricators of spindle bearings oil-mist lubrication, linear guideway and ballscrews of each axis, oil-mist cooling pump (optional) are aggregated at one place for easy adjustment and maintenance.

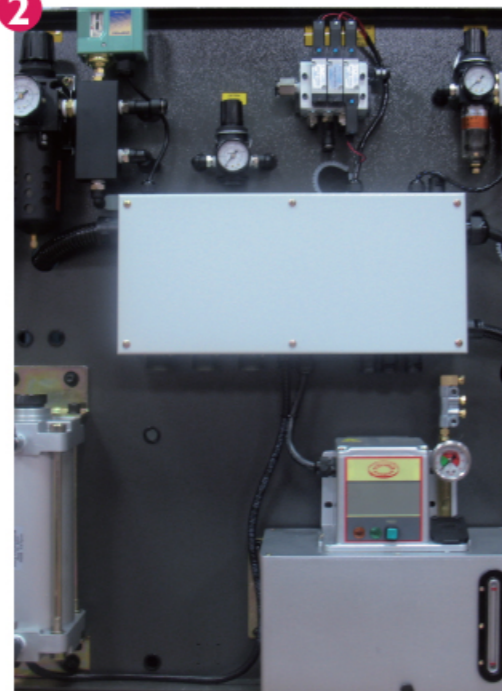

## 3. Air Conditioner

With the use of air conditioner, the controller, motor driver and electronic components may maintain a constant temperature, this eliminates trouble or machine down-time caused by high temperature for lengthy operations.



## 4. Caterpillar type chip conveyor and cart (optional)

Effectively moves the chips out from machine to avoid potential faults caused by accumulated chips.

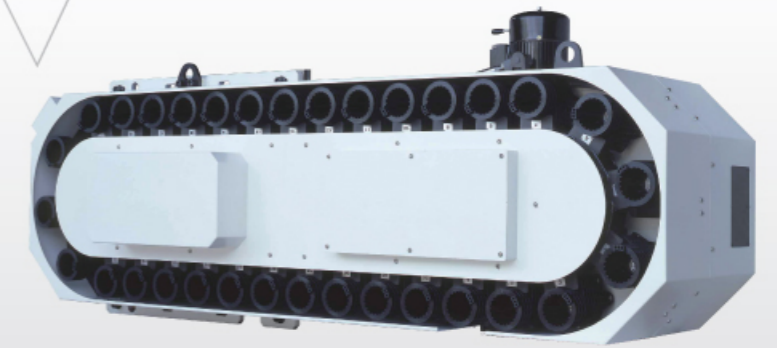

## Tool Magazine

The disk type magazine is driven by a Genova intermittent mechanism for tool change. It employs a spring clamping mechanism to clamp tools securely when the tool disk is rotating. Standard loading capacity of the magazine is 16 tools (Chain Type 40 ATC Unit)

## ▶ Cooler

High efficiency spindle cooling system effectively uses circulating oil / water to remove the heat produced from spindle rotation. This will keep the spindle operation consistently under room temperature to elongate the life of spindle and to increase machining accuracy.

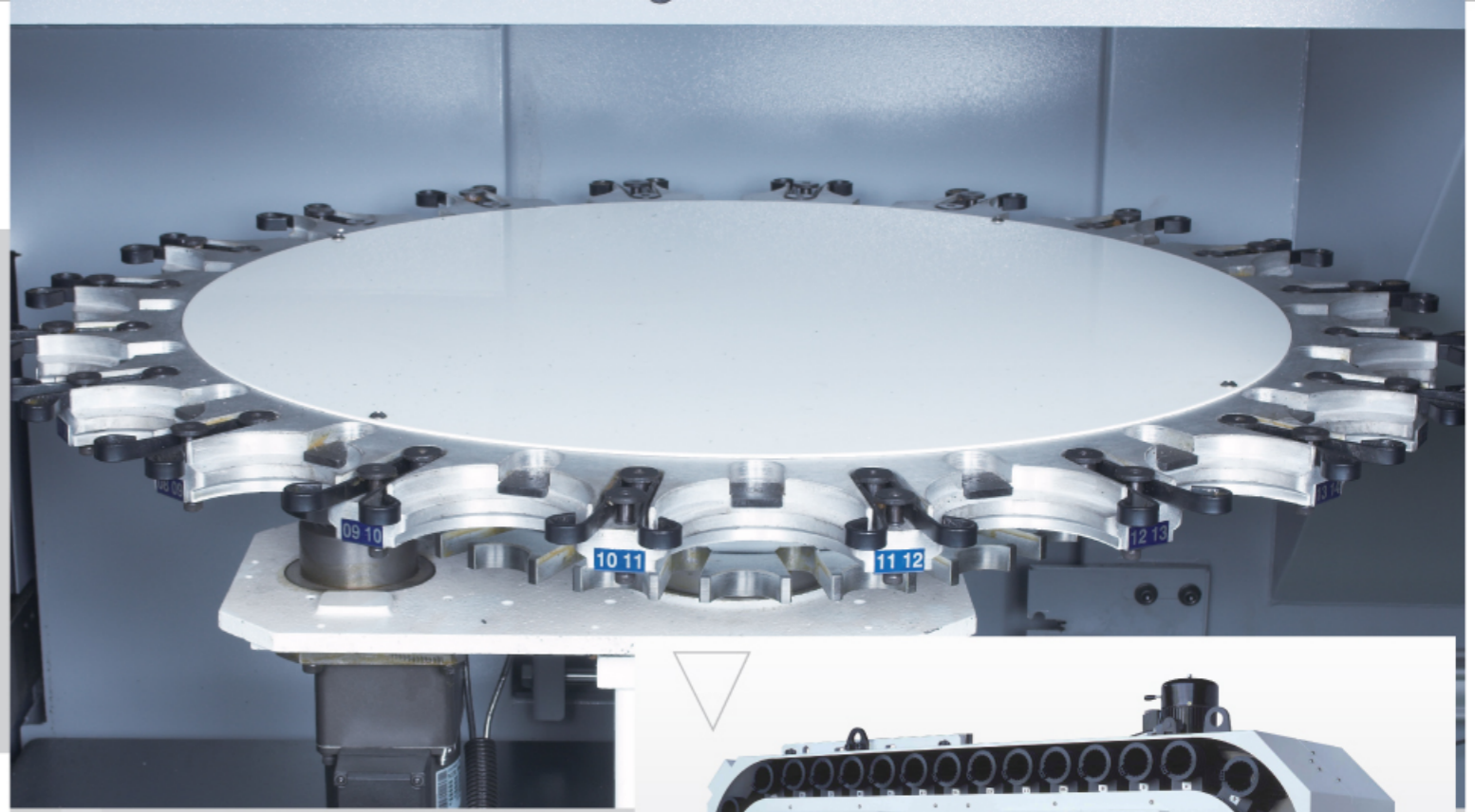

# Optional Equipment

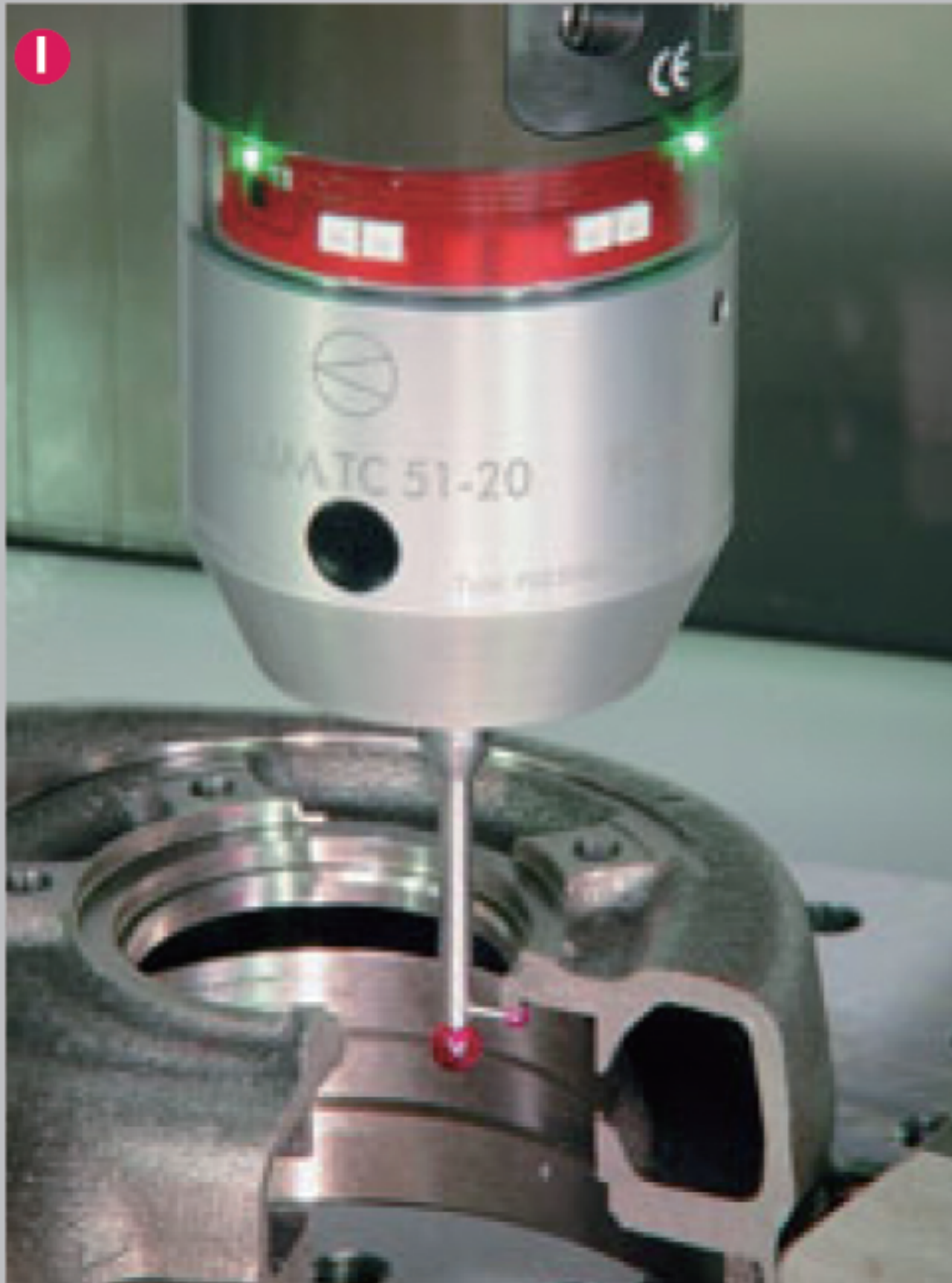

1. Automatic workpiece measurement system
2. CTS coolant through spindle device
3. Oil fluid separator
4. Automatic tool length measurement system (laser type)
5. Automatic tool length measurement device (mechanical type)

## Various Advanced CNC Controls to Choose from

The Gentiger machining center provides a choice of various advanced CNC controls. Each control permits high speed milling and NURBS curved surface machining functions; easy to learn and operate.



SIEMENS 828D / 840D CONTROL  
(Standard Equipment)



FANUC 0iMD / 31iMB HPCC CONTROL  
(Optional Equipment)



HEIDENHAIN iTNC 530 CONTROL  
(Optional Equipment)



MITSUBISHI M70 / M700 CONTROL  
(Optional Equipment)

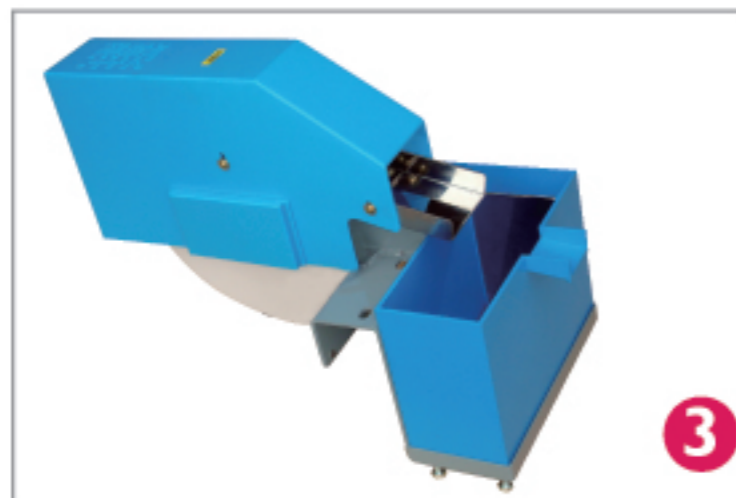

## Ethernet Support Function

The machining programs can be managed by a PC with instant editing; then programs are transferred through Ethernet to the machine. This function will save operation time.



# Minimum Footprint

# Maximum Working Area

### ▶ Tool Shank Diagram

BT-40

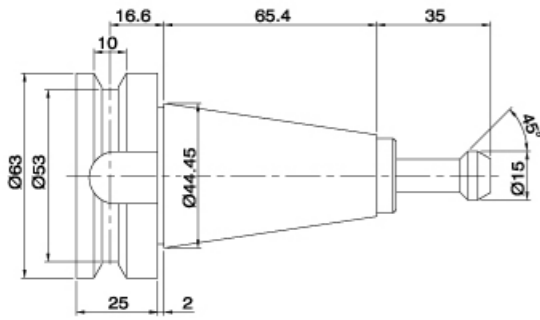

HSK-A63

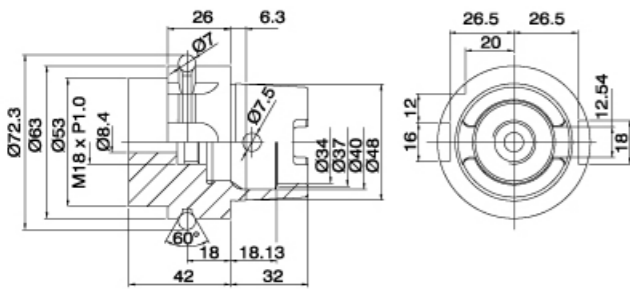

### ▶ Workpiece Drawings Unit : mm

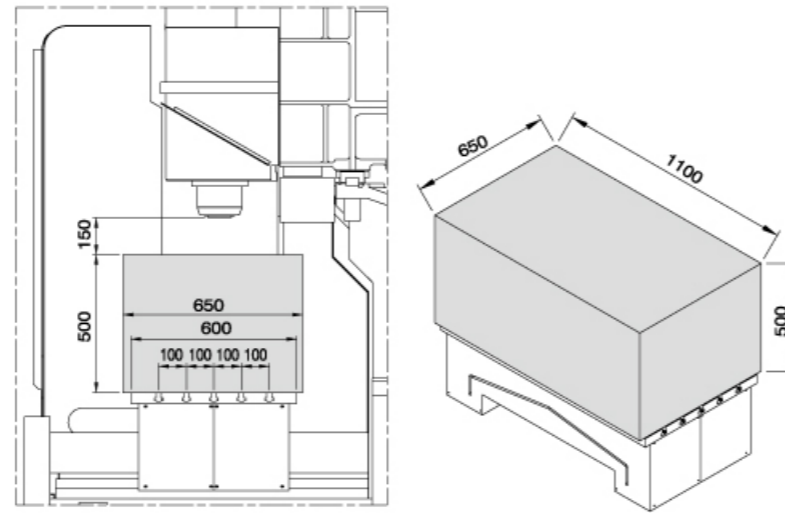

Average load = 1000kg

### ▶ Dimensional Drawing of Machine Unit : mm

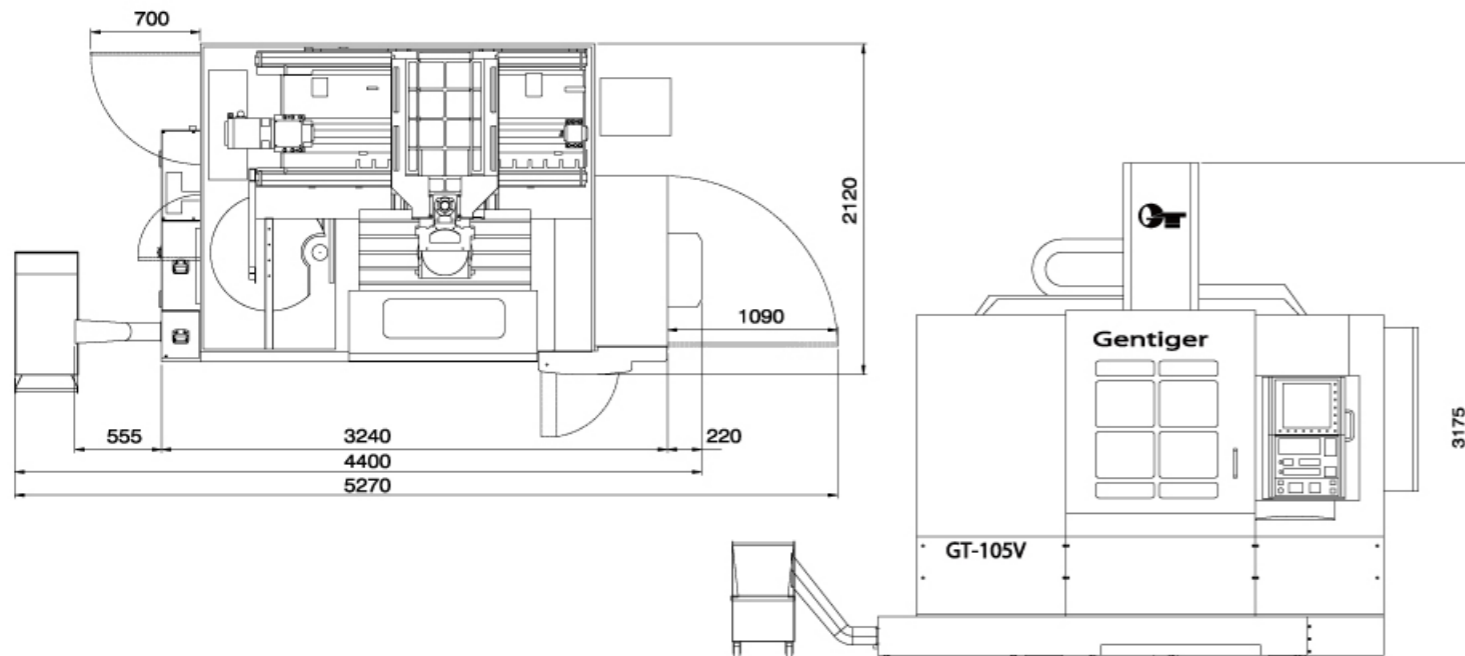

## GT-105V

| Model                                         | T15                     | Y24A                                | S24A          |
|-----------------------------------------------|-------------------------|-------------------------------------|---------------|
| Inner dia. of spindle bearing                 | Ø70                     | Ø65                                 | Ø65           |
| Max. spindle speed                            | 15,000 rpm              | 24,000 rpm                          | 24,000 rpm    |
| Spindle taper                                 | BBT / BT-40             | HSK-A63                             | HSK-A63       |
| Spindle motor                                 | 11 kW                   | 18 / 23 kW                          | 30 / 39 kW    |
| Bearing lubrication                           | Grease / Oil-air (opt.) | Oil-air                             | Oil-air       |
| Spindle cooling                               | Oil-cooling             | Water-cooling                       | Water-cooling |
| Distance from spindle center to machine front |                         | 700 mm                              |               |
| Table area                                    |                         | 1100 x 600 mm                       |               |
| T-slot                                        |                         | 18 x 5 x 100 mm                     |               |
| Height of table from ground                   |                         | 850 mm                              |               |
| Max. load of table (Average load)             |                         | 1000 kg                             |               |
| Travel for X, Y and Z axis                    |                         | 1000 x 600 x 500 mm                 |               |
| Distance from table surface to spindle nose   |                         | 150-650 mm                          |               |
| Rapid feedrate                                |                         | 30 m / min                          |               |
| Cutting feedrate                              |                         | 20 m / min                          |               |
| ATC tool system                               | BBT / BT-40             | HSK-A63                             | HSK-A63       |
| Magazine capacity                             |                         | 16 Tools (opt.: 20 / 24 / 40 Tools) |               |
| Max. tool length                              |                         | 250 mm                              |               |
| Max. tool weight                              |                         | 8 kg                                |               |
| Motor of tool magazine                        |                         | 60 W                                |               |
| X, Y & Z axis servo motors                    |                         | X-5.7 kw, Y-5.7 kw, Z-5.7 kw        |               |
| Air pressure requirements                     |                         | 7 kgf / cm <sup>2</sup>             |               |
| Air conditioner                               |                         | 750 W / 550 W                       |               |
| Spindle cooler                                | 1950 W                  | 2650W                               | 2650 W        |
| Chip conveyor                                 |                         | 180 W                               |               |
| Automatic lubricator (slide ways)             |                         | 150 W                               |               |
| Coolant motor                                 |                         | 750 W                               |               |
| Chip flush motor                              |                         | 1580 W                              |               |
| Total power                                   | 35 KVA                  | 41 KVA                              | 40 KVA        |
| Coolant tank                                  |                         | 180 liter                           |               |
| Packing dimensions                            |                         | 4030 x 2300 x 3580 mm               |               |
| Net weight                                    |                         | 8,600 kg                            |               |
| Gross weight                                  |                         | 9,600 kg                            |               |

▷ SIEMENS control is standard. HEIDENHAIN, FANUC and MITSUBISHI control are optional.

▷ Above specifications are subject to change without prior notice.

### STANDARD ACCESSORIES

- Coolant Tank
- Work lamp
- Toolbox
- Chip flush motor
- Coolant motor
- Coolant system
- Spindle air blow system
- Chip air blow device
- Y-axis telescopic covers
- Air conditioner for electrical cabinet
- MPG
- M30 work end indication light
- Spindle cooling system
- Full enclosed splash guard
- Leveling bolts and pads
- Central control lubricator
- Operation and maintenance manuals
- Screw type chip conveyor and cart
- Network function
- Spindle temperature compensation system

### OPTIONAL ACCESSORIES

- Coolant through spindle
- Three axes optical scales
- Oil and lubricant separator
- Oil mist cooling system
- Oil mist collector
- Auto tooling measurement
- Auto workpiece measurement
- Caterpillar chip conveyor and cart
- X axis telescopic cover
- Graphite dust collector
- Transformer
- Chain Type 40 ATC Unit